

DynaLogger HF+S

PN 101112-PO | NCM 9027.89.99 | HS 902789

Datasheet Set. 2023











Overview

The **HF+s** DynaLogger is designed to identify failure mode symptoms or defects in machinery and equipment in a **wide variety of field applications**. Due to its **broad frequency spectrum**, the **HF+s** delivers complete triaxial vibration and temperature monitoring for **low to high-speed equipment**. In addition, the solution features an **online platform**, which does not require local installation, with several tools that assist in data analysis and enable constant monitoring of asset health.

The **HF+s** DynaLogger has two monitoring modes: spectral/waveform and telemetry. **Telemetry monitoring**, configurable in bands, includes several metrics such as acceleration, velocity, and RMS displacement, peak, peak-to-peak and crest factor, as well as skewness, kurtosis, and contact temperature. In **spectral monitoring**, different tools can be used: spectrum, waveform (linear, circular and orbital), frequency filters, cepstrum, spectral envelope (demodulation), autocorrelation and multi-metrics.

Wireless Monitoring Solution

-  Compact sensor with wide frequency range.
-  Long battery life.
-  High frequency and amplitude resolution.
-  Over 40 telemetry metrics that can be applied in different frequency bands up to 13 kHz (under development).
-  Low-speed applications (less than 10 RPM).
-  Sensor with low spectral noise.
-  Truly simultaneous triaxial measurement.
-  Remote sensor update.

Main assets monitored

- Motors
- Pumps
- Fans
- Gearboxes
- Rollers and Brakes
- Compressors and chillers
- Wind turbines
- Bearings in high and low-speed assets



Technical Specifications

Model	HF+s
Dimensions	39 x 39 x 35 mm
Weight	73 g
Case material	LEXAN™
Material of pin and base	INOX 316L
Color	Blue
Mounting	Glued or Screwed
Visual Signaling (LED)	Red / Green
Accelerometer	MEMS Triaxial
Accelerometer Impact Limit	10,000 g in 0.2 ms
Operating temperature^{1,2}	-10°C ≤ T ≤ 84°C
Certified operating temperature for use in explosive atmosphere	-10°C ≤ T ≤ 79°C

Certification

Homologation / Certification	ANATEL
Protection Degree	IP66/IP68/IP69
Explosive Atmosphere	Ex ma IIB T6 Ga Ex ta IIIC T85°C Da

Battery

Voltage	3 V
Autonomy³	3 to 5 years

Continuous Monitoring (Telemetry)

Sampling Period	1 to 60 min
Monitored Metrics *Under development	RMS Acceleration, Peak* and Peak-to-Peak*
	RMS Velocity, Peak* and Peak-to-Peak*
	RMS Displacement, Peak* and Peak-to-Peak*
	Acceleration Skewness
	Acceleration Kurtosis*
	Acceleration Crest factor (CF)*
	Acceleration Crest factor + (CF+)*
	Contact Temperature
Temperature resolution	0.01°C
Frequency Bands	2 Hz to 13 kHz (configurable)
Monitoring Profiles⁴	2 profiles
Frequency Response (± 3 dB)	7.6 kHz
Amplitude Range	Up to ±16 g
Memory⁵	51,200 samples (configurable)

Communication and System

Bluetooth	BLE 5.3 / 2400 - 2483,5 MHz
Free Field Range⁶	100 m
RF Output Power	0.4 dBm
App Communication	Android and iOS

1 It is possible to monitor assets whose temperature exceeds 84°C, especially assets with intermittent characteristics and with room temperature below 24°C. However, Dynamox does not provide warranty in these cases. Specific condition for application outside explosive atmospheres. **2** The application at temperatures below 0°C impacts the battery autonomy. This effect worsens the lower the temperature, estimating a reduction of about 50% of useful life in applications at -20°C. Specific condition for application outside explosive atmospheres. **3** Estimated value for a standard monitoring condition with 1 or 2 daily spectral collections, telemetry intervals of 5 to 30 minutes and operating temperature between 20°C and 60°C. **4** Monitoring profiles can be understood as set configurations of vibration metrics (in velocity, acceleration and displacement) in a given frequency band. **5** Each telemetry metric corresponds to the allocation of a sample in memory. In practice, the time to fill the memory depends on the sample interval and number of metrics configured. It is important to remember that when a data collection is performed (App or Gateway), the memory is emptied.

6 Reference in free field. Bluetooth communication distance may vary with obstacles, interference and device (cell phone or Gateway)



Spectral Monitoring and Waveform

Analysis Tools	Spectrum
	Frequency filters
	Envelope (demodulation)
	Cepstrum
	Spectral Waterfall
	Autocorrelation
	Circular and orbital waveform
	Advanced metrics: multiband RMS, peak-to-peak, Kurtosis, CF, CF+, Carpet Energy, and RMS Envelope.
Frequency Response ($\pm 5\%$)	7 kHz
Frequency Response ($\pm 3\text{dB}$)	7.6 kHz
Spectral noise density	< 75 $\mu\text{g}/\sqrt{\text{Hz}}$
Sample Rate	Up to 26 kHz
Minimum Frequency Resolution	0.006 Hz (8 bits) and 0.012 Hz (16 bits)
Minimum Amplitude Resolution¹	16 μg (8 bits) and 61 μg (16 bits)
Amplitude Range	Up to $\pm 16\text{ g}$
Lines of Resolution (LOR)	98,304 (uniaxial) and 32,768 (triaxial)
Maximum Frequency	571 Hz to 13 kHz (configurable)
Maximum Collection Time²	172.2 s (uniaxial) and 57.3 s (triaxial)

Spectral Monitoring Settings

Simultaneous Triaxial

Max. Freq. (Hz)	Duration (s)						Min. RPM ³
	0.08	0.16	0.31	0.62	1.25	2.5	
13,145	0.08	0.16	0.31	0.62	1.25	2.5	24.0
6,572	0.16	0.31	0.62	1.25	2.5	5.0	12.0
2,629	0.4	0.8	1.6	3.1	6.2	12.5	4.8
1,314	0.8	1.6	3.1	6.2	12.5	24.9	2.4
571	1.8	3.6	7.2	14.3	28.7	57.3	1.0
No. Lines	1,024	2,048	4,096	8,192	16,384	32,768*	-

Uniaxial

Max. Freq. (Hz)	Duration (s)								Min. RPM ³
	0.08	0.16	0.31	0.62	1.25	2.5	3.7	7.5	
13,145	0.08	0.16	0.31	0.62	1.25	2.5	3.7	7.5	8.0
6,572	0.16	0.31	0.62	1.25	2.5	5.0	7.5	15.0	4.0
2,629	0.4	0.8	1.6	3.1	6.2	12.5	18.7	37.4	1.6
1,314	0.8	1.6	3.1	6.2	12.5	24.9	37.4	74.8	0.8
571	1.8	3.6	7.2	14.3	28.7	57.3	86.0	172.0	0.3
No. Lines	1,024	2,048	4,096	8,192	16,384	32,768*	49,152	98,304*	-

1 - Calculated amplitude resolution is based on the accelerometer digital output in $\mu\text{g}/\text{LSB}$ or mg/LSB .

2 - Check the setting in the 'Spectral Monitoring Settings' table.

3 - Minimum RPM based on the longest measurement considering one full revolution of the shaft.

* - Setting available with 8 bits of amplitude resolution



Geometric dimensions

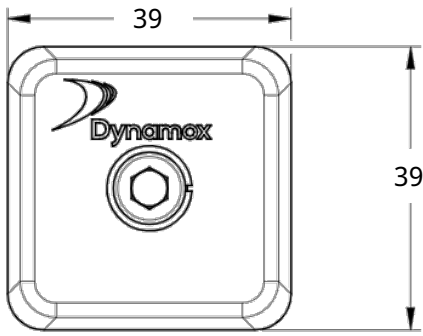

Dimensions in millimeters

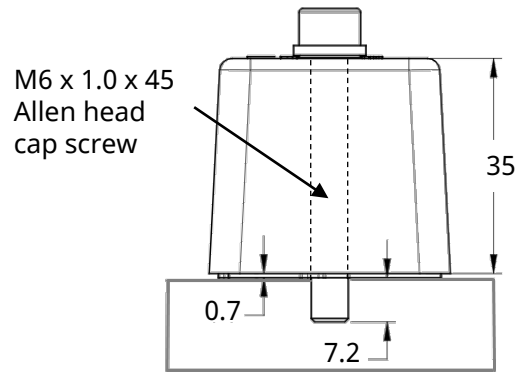

Quick Mounting Guide

- Define the critical points of the machines to be monitored for the installation of the DynaLoggers.
- It is only necessary to install one DynaLogger per monitoring point, because the devices are triaxial.
- Avoid installation in areas of the housings that present any stiffness loss. Example: cooling fins, covers, and protections. Try to install in rigid parts of the machine, preferably near the bearings.
- Align one of the axes of the DynaLogger with the actual axis of the machine. These axes are shown in the schematic above and on the body of the devices. A detailed installation guide can be found at [Dynamox's support website](#).

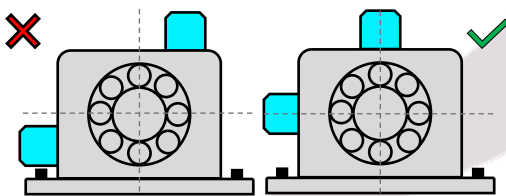

It is recommended, as far as possible, to install the DynaLoggers centrally on the component.

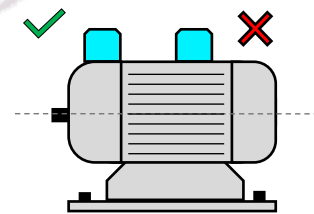

Installation on cooling fins and covers is not recommended. Note: For motors, it is recommended to install a sensor on the drive end and another one on the non-drive end for complete monitoring.

Regarding the types of mounting, the HF+s DynaLogger can be:

Screwed: M6 screw with a length that allows a minimum 7.2 mm depth to the drilled surface. It is recommended to use a spring washer and to apply an 11 N-m torque.

Glued: After cleaning the mounting spot, apply adhesive glue to cover the entire sensor base. Dynamox recommends the adhesives DP8810, DP8710 and DP420 from 3M.

Magnetic Base: It can be used in specific cases where easy removal is desired. Not recommended for permanent installations, due to loss of high frequency response.





© 2023, Dynamox®. DynaPredict® is a registered trademark of Dynamox. All rights reserved.

The contents of this publication are presented for informational purposes only. Every care has been taken to ensure the validity of the information contained in this publication, but no liability can be assumed for any loss or damage whether direct, indirect or consequential arising out of the use of the information contained herein. We reserve the right to modify or improve the specifications of our products at any time without notice.

Contact Us
 <https://dynamox.net/en/contact>

DAT-HF+S:092023-01/EN - [PUBLIC DOCUMENT]

